

Installation Instructions

Upper Door Skin

97-06 Jeep Wrangler

IMPORTANT NOTICE:

Carefully read instructions before attempting to install this product. Rough Trail is not responsible for any damage to the vehicle or personal injury that may occur during the installation or use of this product.

WARNING

This product is designed to enhance the appearance of the vehicle and only for protection against the elements. Do not rely on this product to contain occupants within the vehicle or to protect against injury during an accident.

WEAR SEAT BELTS AT ALL TIMES

UPPER SKIN INSTALLATION TIPS

To help ease the installation, be sure to install the Upper Skins when temperatures are above 70° F. The material shrinks substantially at lower temperatures and may become difficult to install. The Skins may seem wrinkled when first installed; this is caused by the fabric becoming wrinkled in shipping. It will relax after a few days on the vehicle. Unfortunately, over the years, many different companies have produced upper door frames, and while they are similar, the exact dimensions will vary, which may require additional adjustments in installation. The skin may appear tight at first, but will stretch and adjust into position as indicated thru steps 1 to 4 in the attached illustration – please insure the window is unzipped while wrapping the skin over the frame.

Upper Window Skin Installation

1. After removing Upper window Skins from packaging, leave the skins out in sunlight for at least one hour (above 70° F).
2. Remove old window skin from frame (cutting may be required).
3. Un-zip (open) window on skin to help ease installation.
4. Install upper skin on frame in the order shown below **Figure 1**.
5. Adjust skin and tighten Velcro.

(WINDOW FRAME SHOWN FOR INSTALLATION, NOT INCLUDED)

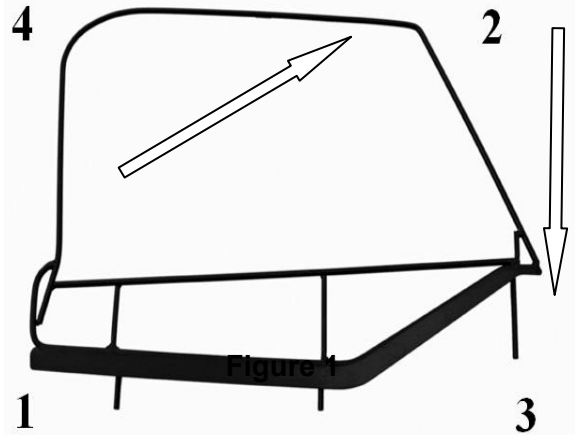

LIMITED 1 YEAR WARRANTY

Applies to Upper Door skins by Rough Trail

Rough Trail (the company) warrants to the original purchaser of this product that should the product or any part thereof, under normal use and conditions, be proven defective in material or workmanship within 90 days from the date of original purchase, such defect(s) will be repaired or replaced (at the Company's option) without charge for parts or repair labor. Please note that installation labor to remove or install this product is not covered under this limited warranty.

To obtain repair or replacement within the terms of this Warranty, the product is to be delivered with proof of warranty coverage (e.g. dated bill of sale), specification of defect(s), freight pre-paid to the place of purchase or, you must contact Rough Trail for warranty service or to obtain a Return Goods Authorization Number.

NOTE: Items returned to Rough Trail without an Authorized Returns Good Authorization number will be refused and returned back to sender at the sender's expense. Some states do not allow limitations on how long an implied warranty lasts or the exclusion or limitation of incidental or consequential damage, therefore above limitations may not apply to you. This Warranty gives the purchaser specific legal rights. The purchaser may have additional rights, which vary from state to state.